

Concepts

Products

Service



Limitless Perfection.

Lindner partition wall systems - the ultimate in quality, the most extensive range.



Lindner

Building New Solutions

Building new solutions.

Lindner undertakes major worldwide projects in all areas of interior finishes, insulation technology, industrial services and building facades. From pre-planning through to project completion Lindner is your partner of choice.

The Company's extensive manufacturing capability enables quality to be strictly maintained whilst allowing maximum flexibility to meet individual project requirements.

Environmental considerations are fundamental to all Lindner's business principles.

Through partnerships with clients Lindner turns concepts into reality.

Choosing Lindner you have:

Lindner Concepts:

Tailored solutions specifically geared to satisfy individual project requirements

Lindner Products:

Quality materials and systems to the very highest industry standards

Lindner Service:

Comprehensive project management services

Be

inspired!

Nothing is impossible with
Lindner partition walls.

First-class prerequisites for your interiors:

- Excellent product quality
- Extensive range
- Innumerable combinations with all partition wall systems
- Innovative customised solutions
- Everything under one roof

Lindner will make your project a success.

Lindner works alongside architects and clients on interior fit-out projects across the globe.

Lindner provides all its associated services from one source - either individually or as 360-degree customer care. This is why we can implement especially efficient procedures to complete even very complex construction projects.



Lindner also manufactures its partition wall systems in its main plant in Arnstorf.

Convincing quality: Lindner products.

Lindner manufactures a large proportion of its products here in Arnstorf. Lindner partition wall systems and perfectly coordinated doors are also manufactured in-house. Lindner's international buying department works closely with selected partner companies to ensure that it can provide you with the best possible quality, quickly and at competitive prices - both for Lindner standard systems and for Lindner customised solutions.

Lindner's expertise in partition wall systems:

- In-house production lines
- Many years of experience
- Knowledge and expertise of non-standard projects
- Rapid response times for specific requirements
- Quick, professional delivery and installation

Guaranteeing the perfect solution: Lindner research and development.

Every project has its own specific requirements in terms of construction, structural performance, acoustics, fire protection and design. Lindner's in-house research and development department will meet your exact requirements. Lindner would be pleased to develop innovative ideas with you - after all Lindner's strength lies in „Building new solutions“.



Lindner has its own in-house TÜV-certified sound laboratories, in which it tests its products' absorption and sound insulation properties.

Professional installation of every product.

Do you require products and installation from one source? Contact Lindner: the Lindner team would be pleased to assist. Lindner partition walls and doors are particularly straightforward to install - for a versatile system, installed without a hitch!

Lindner will take responsibility.

Lindner gives top priority to across-the-board quality assurance on all its procedures and processes. This ensures that Lindner will always supply you with exceptional products and services. Occupational health and safety and environmental conservation are among the key aims of the company: for this reason, the Lindner integral quality assurance system automatically incorporates all ecological and safety issues.

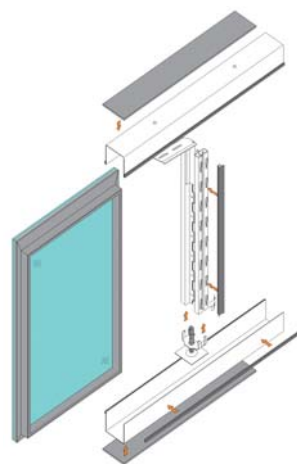

Lindner glass partition wall

The right partition wall for every space.

Lindner will find the perfect solution for your project, in terms of design, versatility, security and acoustics.

Discover the wealth of designs – Lindner will happily produce fully-glazed and partially-glazed partition walls, solid and lightweight walls.

We will put our hands into fire to ensure your safety.

Lindner products meet the most exacting fire-proofing standards - and so provide you with the maximum safety.

Keeping an open ear to acoustic requirements.

Lindner partition walls ensure the best possible sound-proofing in every office and thus provide ideal working conditions. Even on complex projects, such as function rooms, theatres and studies, you can rely on Lindner: Lindner's comprehensive knowledge and expertise, combined with its high-quality products, will guarantee the best possible room acoustics and ensure that you can understand when someone is speaking.

Dockland, Hamburg





Chamber of Commerce, Bozen

Lindner systems combine perfectly with each other - for greater diversity and versatility in your design.

In the work place, space requirements can often change quickly. Lindner partition walls can be quickly and easily adapted to new situations - all systems are constructed to a similar basic design and are easily accessed for service and maintenance. A further advantage is that Lindner system solutions can be almost unrestrictedly combined with each other, with the result that you can benefit from a huge range of combination options.

Your ideas perfectly transformed into reality. With Lindner's four product areas:

Lindner Logic

- Timber partition walls
- Metal partition walls

Lindner Life

- Glass partition walls

Lindner Free

- Timber fascia panels
- Metal fascia panels
- Glass fascia panels

Lindner Plus

- Doors
- Accessories

Lindner Logic: ready for anything.

Lindner Logic partition walls are real all-rounders: they are versatile to use, quick to install and can be designed to meet your specific requirements.



Most designs can be achieved with a wide range of materials, finishes and coatings – with a prestigious timber or metal appearance. Neither do you need to sacrifice transparency: simply combine your partition walls with glazing. Lindner will be pleased to assist in the design and selection.



Children's and women's clinic, Dresden



Campeon, Munich

„Part-time“ offices: Lindner Logic 670.

These versatile free-standing partitions separate work spaces and provide effective sound-proofing and visual privacy. At the same time they are remarkably easy to access for service and maintenance, as they are installed without floor plugs. Visually the system is also exceptionally adaptable: it can be manufactured as full-height or half-height panels in every colour and material.

Achieving the best result together.

Lindner works closely with its customers in the development of innovative solutions, for example our partition wall system Logic 670: Designed initially as a customised product, this system is now an integral part of our range. Perfect teamwork – for creative „Building new solutions“!

Transparent elegance: Lindner Life.

Lindner Life glass partition walls – outstanding for all living and working spaces.

Glass will give your walls a high-quality appearance and create bright, open spaces. Its sound-proofing properties will enable you to work undisturbed and in peace - ideal conditions for an office.

Create visual features: glass partition walls with non load-bearing frames.

Are you trying to achieve a sophisticated and prestigious look? Then simply opt for glass partition walls with aluminium frames on both sides. The slender width of the panel will not fail to win you over. You can choose from different surface designs with single or double glazing - to meet your exact requirements.

And if you want the same in green? Or yellow? Or in red? Or in blue?

Irrespective of whether you want to create colourful contrasts, incorporate stencilling or back-painted partition walls – glass offers you almost unlimited options. A whole host of techniques can be applied in terms of design: screen printing, etching, enamelling or the application of film. Give your imagination free rein!



Keeping offices beautifully quiet: glass partition walls with front-mounted glazing.

These will transform your rooms into quiet zones: front-mounted glazing will provide you with the ultimate in sound-proofing up to more than 50 dB.

Lindner quality – tailored to your needs:

- With single or double glazing
- Frames with different depths
- A wide range of styles
- Can be combined with electric blinds
- Complies with fire protection regulations



Barmenia, Wuppertal



Plange Muehle, Düsseldorf

Photo: H. G. Esch, Hennef

Gaining insight: glass partition walls with flush glazing.

These partition walls are supplied without frames - thanks to the latest structural glazing technology. The slimline glazing profile gives a discreet appearance. A further advantage is that the smooth surface makes the glazing especially simple and easy to clean. This partition wall can also be supplied to comply with fire-proofing regulations, if required.

Convey a delicate appearance: glass partition walls with slimline glazing.

The filigree look of this frameless partition wall with its particularly slender profile cannot fail to impress you. Lindner will be happy to manufacture this partition wall with single or double glazing, highly sound-proofed or to conform to fire-proofing regulations.

A real eye-catcher: Lindner fully-glazed partition walls.

Fully-glazed partition walls are as elegant as they are inexpensive. Their design, completely free of uprights, creates an impression of airiness and spaciousness, while the silicone-joined glazed panels create an outstandingly smooth line. These partition walls meet the most exacting building regulations, even without vertical uprights - and are impressive on all counts:

- Maximum transparency
- A range of glazing designs
- Designs can also include air transfer diffusers, sound absorbers, pivot and sliding doors

Business Centre II, Bratislava

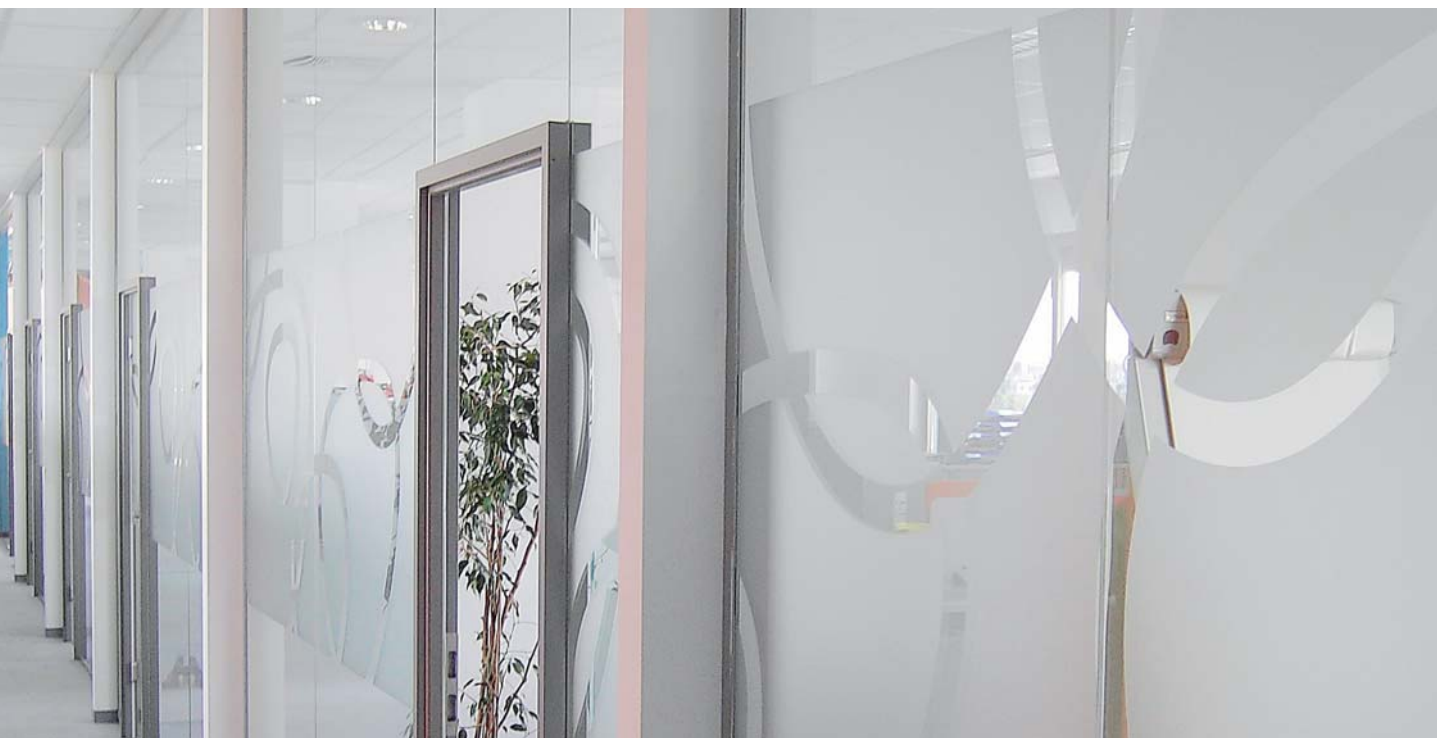

An air of peace: acoustic transfer diffuser.

To ensure air exchange between offices and corridors, fully-glazed partition walls can be provided with air transfer diffusers. Absorbent elements integrated within the air duct prevent the transmission of voices – for quiet and confidentiality in all areas of your company.

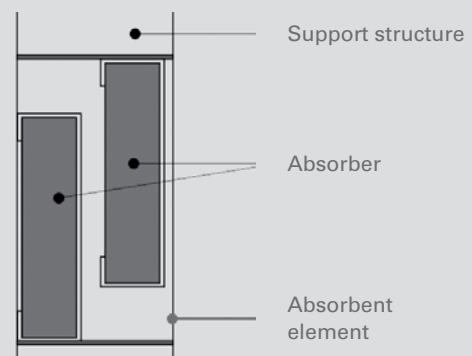

Ensuring your space has simply beautiful walls: Lindner Free.

You can transform every brick or concrete wall, pillar or column into an eye-catching feature with Lindner Free fascia panels.

Take advantage of the creative freedom that glass, timber, metal and aluminium can offer you. Lindner Free products are fully accessible for service and maintenance and can also be combined with functional properties - such as effective impact protection or outstanding sound absorption.

Our understuctures will see you through thick and thin.

Fascia panels can be fitted to the unfinished wall leaving either a very small or relatively large gap. This will allow you either to save space or conceal building services, cabling and pipework - Lindner will be happy to discuss the various options with you.

Aluminium fascia panels meet the most exacting requirements in terms of form and aesthetics. They can be fitted to be especially space-saving. A range of colourful styles are also available - such as here in the Trianon, Frankfurt am Main.

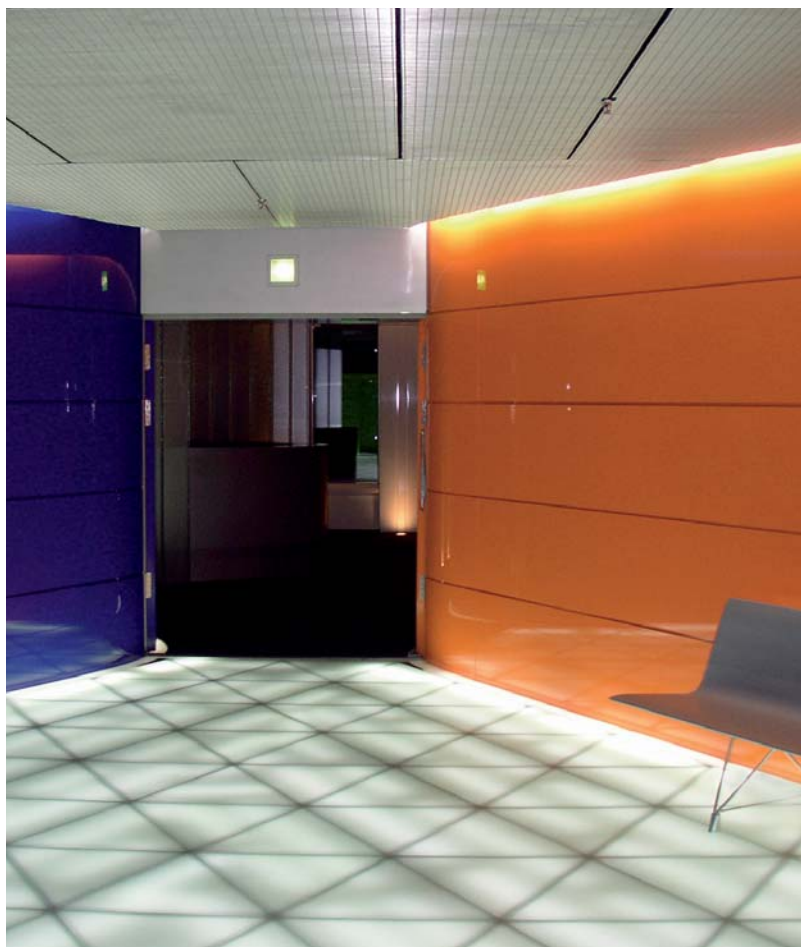

Lindner fitted out the interior of the DKV in Cologne with timber and glass fascia panels. Wood is an extremely high-quality material that creates a warm atmosphere. A number of various designs can be created by using different panel arrangements. Glass is an exceptionally diverse material - it can be designed using a range of different techniques.



The metal fascia panels in the Tobacco Corporation in Shanghai stand out because of their outstanding and fresh design.



An imposing appearance: metal fascia panels.

Lindner uses in-house manufactured steel panels with plasterboard inlays for its metal solutions. Lindner can also manufacture these high-quality products to provide effective sound-proofing. You can turn your ideas into reality with a wide range of finishes and colours - even by using real wood.

For Adidas, Lindner produced fascia panels with in-house manufactured metal shells
Photo: Adi Dassler Brand Centre, Herzogenaurach)



The perfect accompaniment to your walls: Lindner Plus.

To ensure that your space has a cohesive design, Lindner can also provide a range of coordinated doors and accessories for every partition wall.

Lindner's extensive range of architraves, doors and sliding doors coordinate perfectly with its partition wall systems - as do its wide selection of fixtures and fittings. Make your own mind up over the next few pages.

Lindner will open the door to your inspiration.

Lindner's in-house manufactured architraves and doors mean that it can quickly and accurately meet your needs. Are you planning a non-standard project? Lindner relishes these above everything: its many years of experience and close cooperation between all company departments means that it can meet even very specific requirements in terms of fire protection, sound-proofing, anti-theft protection, radiation protection etc.

A harmonious relationship: Lindner doors and accessories – for a sophisticated result.



Paul Wunderlich House, Eberswalde

Lindner Plus:

- Architraves
- Doors
- Sliding doors
- Electrical supply
- Organisational and acoustic elements
- Blinds

Outstanding framework.

Any conceivable door dimension is possible, as Lindner manufactures its doors in-house. Fan lights and top panels can be manufactured to whatever shape and dimension your project requires. You need not sacrifice functionality: if required Lindner can incorporate locks and switches into your architraves. Speak to Lindner - there are no limits to what you can achieve with your ideas.

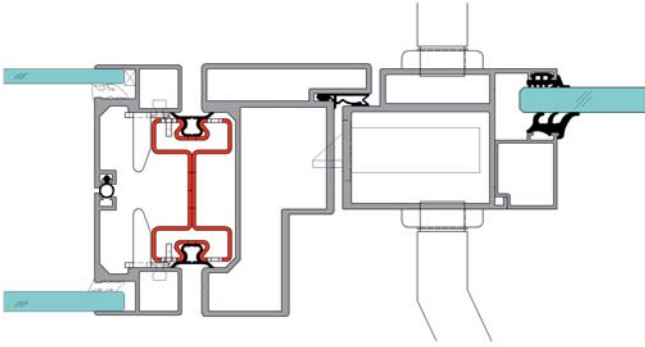

Aluminium architraves for the Campeon in Munich



Barmenia, Wuppertal

However you want to design your space: you will find the right architraves from Lindner, in aluminium, steel and wood, amongst others.

Integral intelligent technology: aluminium architraves with integrated cabling.

Building services are an indispensable component of every interior today. Power and controls cabling can be perfectly concealed in Lindner's patented aluminium architraves. That way you can remain flexible - especially in commercial buildings.

Lindner aluminium architraves provide many advantages:

- Integral electrics and signs
- Filigree, transparent appearance (ideal for glazed partition walls)
- Option without installation panels
- Slimline profiles
- Greater transparency in your building



Campeon, Munich

Creative ideas - door by door.

It is completely up to you whether you want to be able to look through your doors or create colourful features with different finishes. Lindner high-quality glass, timber and tubular doors will ensure that you have the choice. Doors can also be designed to meet specific fire-proofing requirements.

We will go the full mile for a balanced design.

Lindner Plus provides all the prerequisites for a coordinated and aesthetic overall look - even with the most demanding building projects, such as the Campeon in Munich. The perfect interplay of partition walls and doors was achieved by the use of aluminium architraves and aluminium tubular door frames.

Lindner undertook the entire interior fit-out for the Campeon, including the supply and installation of wall fascia panels, flexible free-standing partition walls, ceilings and flooring. Lindner was also responsible for the fit-out of the clean rooms - with tailor-made customised solutions and designs.

It always comes down to the detail: Lindner Plus accessories.

Every space has very specific requirements. Using Lindner Plus accessories, you can easily respond to everyday office needs: individual components can be simply and easily integrated into almost all partition wall systems.



You will always find a connection: Lindner facade struts.

Would you like to fix your partition walls or plasterboard walls to a facade with slimline support profiles? Our factory-preassembled facade struts will provide a perfect connection. They can also provide sound-proofing of up to 52 dB. Even if you have other special requirements, Lindner will find a solution - with project-specific customised solutions.

Everything just right: Lindner organisational elements.

Lindner organisational elements will ensure that you never again mislay your books, files or folders, and will also allow you to pin up your notices and calendars.

Keeping offices peaceful and tranquil: Lindner acoustic elements.

Do you need additional sound-proofing? With our acoustic elements you will hear a pin drop. Lindner will find the right product for your room - the right size, right perforation and right design.

Expose yourself to a high protection factor: with Lindner blinds.

All glazed partition walls and doors can be fitted with blinds, to protect you from the sun and to give you privacy. A number of different operating mechanisms are available: electrical, cranks with handles, cords, rods or chains.



Lindner Plus Organisation



Dr. Heidenhain GmbH, Traunreut

Functionality that blends in perfectly with your interior design.

Lindner Plus accessories:

- For the practical design of your interior space
- Extensive range of colours and shapes
- Can be combined with almost all partition wall systems

Your ideas define our objectives: Lindner customised designs.

Are you planning an unusual project? Then Lindner is your professional partner. Even for the most ambitious and unusual building projects, Lindner can develop and produce individual customised solutions. Within the framework of a tailor-made customer-care package, Lindner can offer a wide range of services, such as product development, samples, manufacturing, logistics, installation and maintenance. The result is clear to see, as illustrated by the following examples.

Prestigious interior design with the latest facade technology: Gymnasium II in Erding.

As part of this project Lindner undertook the design of a 10 metre high glazed internal facade, reaching up over 3 floors. The project was successful thanks to Lindner's combination of knowledge and expertise in facade construction and interior fit-out. Glass partitions from the Lindner Life range were stuck together using an innovative structural glazing process which is primarily used for external facades. This enabled Lindner to achieve a rigid structure, complying with all necessary safety regulations. Lindner was also responsible for the complex design of the glazed panels, as well as fire protection and a high level of sound-proofing.

Gymnasium II, Erding



Lindner turns architectural visions into reality.

Lindner complete solutions:

- Integral concepts
- Professional advice
- Extensive purpose-built facilities
- Individual 360° customer care

A stunning role model for customised projects: the University of Bozen.

The interior of the building stands out because of the illuminated glazed partition walls. This outstanding design was made possible by incorporating light boxes directly into the partition walls.

Flush glazed doors with glass bonded to the face of an aluminium frame were a further unusual feature. By incorporating fire hosepipes into the partition walls, Lindner was also able to comply with Italian fire protection regulations. The architraves were fitted with access flaps, providing quick and easy access to the pipes.

University of Bozen, Brixen



We can do it all for you.

Lindner Concepts:

- insulation engineering and industrial service
- clearance of harmful substances
- clean rooms
- airports and airlines
- railways and tunnels
- studios and cinemas
- interior fit-out and furnishings
- cruise liner and ship fit-out
- specialist dry lining
- general contracting
- Public-Private Partnership (PPP)

Lindner Products:

- facades
- ceiling systems
- lights and lighting systems
- partition systems
- doors
- floor systems
- heating and cooling technologies

Lindner Service:

- general planning
- development and design
- delivery
- installation
- maintenance

Lindner

Bahnhofstrasse 29
 94424 Arnstorf
 Germany
 Phone +49 (0)8723/20-36 81
 Fax +49 (0)8723/20-25 47
 partitionsystems@
 Lindner-Group.com
 www.Lindner-Group.com